



Chlorine Disinfection

Project funded by the U.S. Environmental Protection Agency under Assistance Agreement No. CX824652

What is disinfection?

Human exposure to wastewater discharged into the environment has increased in the last 15 to 20 years with the rise in population and the greater demand for water resources for recreation and other purposes. Wastewater is disinfected to prevent the transmission of infectious diseases and to ensure that water is safe for human contact and the environment. There is no perfect disinfectant. However, there are certain characteristics to look for when choosing the most suitable disinfectant:

- ability to penetrate and destroy infectious agents under normal operating conditions;
- lack of characteristics that could be harmful to people and the environment;
- safe and easy handling, shipping, and storage;
- absence of toxic residuals, such as cancer-causing compounds, after disinfection; and
- affordable capital and operation and maintenance (O&M) costs.

What is chlorine disinfection?

Chlorine is the most widely used wastewater disinfectant in the U.S., and it kills most bacteria, viruses, and other microorganisms that cause disease. Chlorine is introduced to wastewater in the form of gas, hypochlorites (tablets, solutions, or powder), and other compounds. The different forms of chlorine used at wastewater treatment plants are gaseous chlorine, sodium hypochlorite solution, calcium hypochlorite, and bromium chloride.

Wastewater and chlorine are first mixed completely in less than 1 second and then enter a baffled contact chamber to allow time for disinfection to occur. The effluent is then discharged to the receiving water.

Chlorine residuals can persist in treated wastewater for many hours. To minimize the effect on aquatic life and the environment, most states require that chlorinated wastewater be dechlorinated. Dechlorination is the process of removing the chlorine residual prior to discharge. Some commonly

used dechlorinating chemicals are sulfur dioxide, sodium bisulfite, sodium metabisulfite, and activated carbon.

See Figure 1 on page 2 for a flowchart of the chlorination process using liquid chlorine and dechlorination using sulfur dioxide.

What are the advantages and disadvantages of using chlorine disinfection?

Advantages

- Chlorine is a well-established technology.
- Presently, chlorine is more cost-effective than other disinfection methods (except when dechlorination is needed and fire code requirements must be met).
- The chlorine residual that remains in the discharged wastewater can prolong disinfection even after initial treatment and also provides a measure of the effectiveness.
- Chlorine disinfection is reliable and effective against a wide spectrum of microorganisms.
- Flexible dosing enables greater control over disinfection since wastewater characteristics vary from time to time.
- Chlorine can eliminate noxious odors while disinfecting.

Disadvantages

- The chlorine residual, even at low concentrations, is toxic to aquatic life and may require dechlorination.
- All forms of chlorine are highly corrosive and toxic. Thus, storage, shipping, and handling pose safety risks.
- Chlorine oxidizes organic matter in wastewater, sometimes creating compounds that could be harmful to humans and the environment.
- The chloride content of the wastewater is increased.
- Certain types of microorganisms have shown resistance to low doses of chlorine.
- The long-term effects of discharging dechlorinated compounds into the environment are unknown.

continued—

This fact sheet was developed by
Clement Solomon, Peter Casey,
Colleen Mackne, and Andrew Lake.

©1998 by the National Small
Flows Clearinghouse



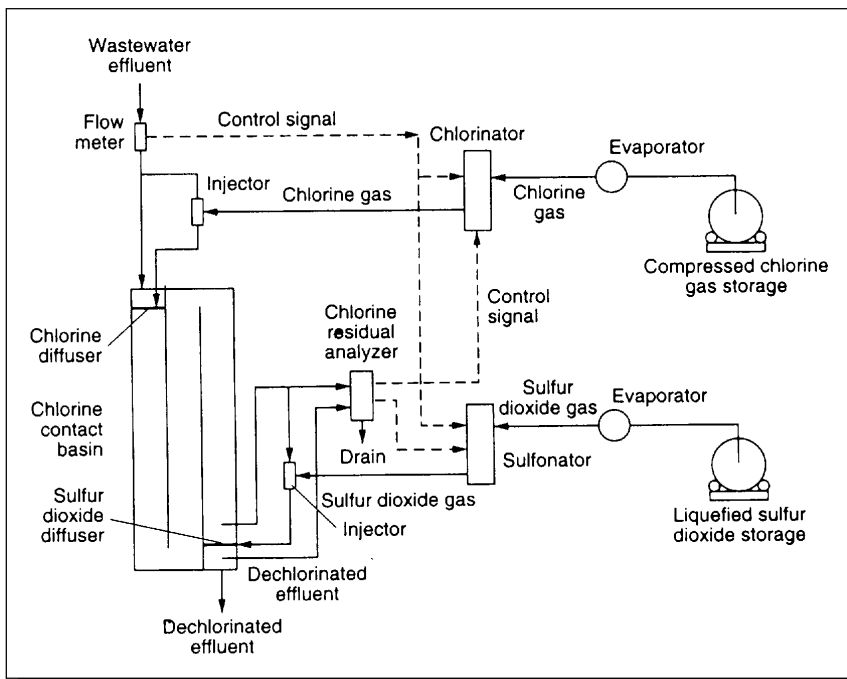

Figure 1:
A compound-loop control system for chlorination with liquid chlorine and dechlorination with sulfur dioxide

Source: Crites and Tchobanoglous (1998), used with permission from The McGraw-Hill Companies

What determines the performance of chlorine disinfection?

The effectiveness of chlorination depends on the dose, the chlorine demand of the wastewater, the chlorine residual, the amount of time the wastewater is in contact with the chlorine, the fecal coliform count in the wastewater, and other wastewater characteristics. The required degree of disinfection can be achieved by varying the dose and the contact time for any chlorine disinfection system. The chlorine dose usually ranges from 5 to 20 milligrams per liter (mg/L).

For optimum performance, the chlorination system must be designed so that the wastewater flows turbulently in a plug flow fashion throughout the contact chamber, ensuring complete mixing. This mixing allows the chlorine to have maximum contact with the wastewater and ensures that there are no dead areas (unused portions) of the tank.

Are chlorination systems easy to operate and maintain?

Chlorine gas is normally stored in steel containers and transported in railroad cars or tanker trucks.

Chlorine is relatively simple to apply and control; however, it is very hazardous, and safety precautions must be exercised during all phases of treatment.

A routine O&M schedule should be developed and followed according to manufacturer's instructions. Regular O&M involves disassembling and cleaning the various components, such as meters and floats, once every 6 months. Valves and springs should also be inspected and cleaned annually. All manufacturer's O&M recommendations should be followed, and

equipment must be tested and calibrated as recommended by the equipment manufacturer.

What is the cost of chlorine disinfection?

The cost of chlorine disinfection systems depends on the manufacturer, the site, the capacity of the plant, and the characteristics of the wastewater to be disinfected.

A study conducted by the Water Environment Research Foundation in 1995 for the average dry weather flow of 1 million gallons per day showed an estimated O&M cost of \$49,300 per year. (A chlorine dose of 5 to 20 mg/L was used from a 1-ton gas cylinder.) The annual O&M costs include power consumption, cleaning supplies, miscellaneous equipment repairs, and personnel costs.

Generally, the total cost of chlorination will increase by about 30 to 50% when adding the dechlorination step. In addition, hypochlorite compounds are more expensive than chlorine gas.

How do I stay informed about chlorination technology?

For more information on chlorine disinfection or a list of other fact sheets, contact the National Small Flows Clearinghouse (NSFC) at West Virginia University, P.O. Box 6064, Morgantown, WV 26506-6064. Phone: (800) 624-8301 or (304) 293-4191. Fax: (304) 293-3161. World Wide Web site: <http://www.nsfv.wvu.edu>.

The NSFC provides free and low-cost informational services and products to help homeowners and small communities address their wastewater needs. Also, information about manufacturers, consultants, regulations, and facilities can be obtained from the NSFC's databases.

References

- Crites, R. and G. Tchobanoglous. 1998. *Small and Decentralized Wastewater Management Systems*. The McGraw-Hill Companies. New York, New York.
- Darby, J.; M. Heath; J. Jacangelo; F. Loge; P. Swaim; and G. Tchobanoglous. 1995. *Comparison of UV Irradiation to Chlorination: Guidance for Achieving Optimal UV Performance*. Water Environment Research Foundation. Alexandria, Virginia.
- Metcalf & Eddy, Inc. 1991. *Wastewater Engineering: Treatment, Disposal, and Reuse*. 3d ed. The McGraw-Hill Companies. New York, New York.
- Task Force on Wastewater Disinfection. 1986. *Wastewater Disinfection*. Manual of Practice No. FD-10. Water Pollution Control Federation. Alexandria, Virginia.
- U.S. Environmental Protection Agency (EPA). 1986. *Design Manual: Municipal Wastewater Disinfection*. EPA Office of Research and Development. Cincinnati, Ohio. EPA/625/1-86/021.

The mention of trade names or commercial products does not constitute endorsement or recommendation for use by the NSFC or U.S. EPA.